



US006700711B2

(12) **United States Patent**
Nalwa

(10) **Patent No.:** **US 6,700,711 B2**
(45) **Date of Patent:** ***Mar. 2, 2004**

(54) **PANORAMIC VIEWING SYSTEM WITH A COMPOSITE FIELD OF VIEW**

(75) **Inventor:** **Vishvjit Singh Nalwa, Holmdel, NJ (US)**

(73) **Assignee:** **Fullview, Inc., Holmdel, NJ (US)**

(*) **Notice:** Subject to any disclaimer, the term of this patent is extended or adjusted under 35 U.S.C. 154(b) by 0 days.

This patent is subject to a terminal disclaimer.

(21) **Appl. No.:** **10/093,568**

(22) **Filed:** **Mar. 8, 2002**

(65) **Prior Publication Data**

US 2002/0089765 A1 Jul. 11, 2002

Related U.S. Application Data

(63) Continuation of application No. 09/431,400, filed on Dec. 27, 1999, now Pat. No. 6,356,397, which is a continuation of application No. 08/946,443, filed on Oct. 7, 1997, now Pat. No. 6,111,702, which is a continuation-in-part of application No. 08/565,501, filed on Nov. 30, 1995, now Pat. No. 6,115,176.

(51) **Int. Cl.⁷** **G02B 13/06; G02B 23/08; H04N 7/00**

(52) **U.S. Cl.** **359/725; 359/363; 359/403; 353/94; 348/36**

(58) **Field of Search** 359/362-363, 359/367, 399, 402-403, 725-732, 831-837; 348/36-39; 353/30, 94, 98-99; 352/69-71

(56) **References Cited**

U.S. PATENT DOCUMENTS

5,187,571 A * 2/1993 Braun et al. 358/85

* cited by examiner

Primary Examiner—Thong Nguyen

(57) **ABSTRACT**

Cameras are positioned so that at least a portion of the field of view of at least one camera is redirected by a reflective surface. Images from these cameras are merged to produce a composite image while disregarding at least a portion of a camera's field of view such that there is at least one blind region in the composite field of view. Advantageously, such blind regions can be made to encompass edges of mirror surfaces that would otherwise produce image artifacts in the composite image; this can be accomplished without introducing gaps in the angular span of the composite field of view. Data representative of the composite image is stored in a memory from which it may be retrieved selectively using a control means to display a portion of the composite image. The image and control data may be transmitted over a communication network to facilitate remote control and display.

39 Claims, 8 Drawing Sheets

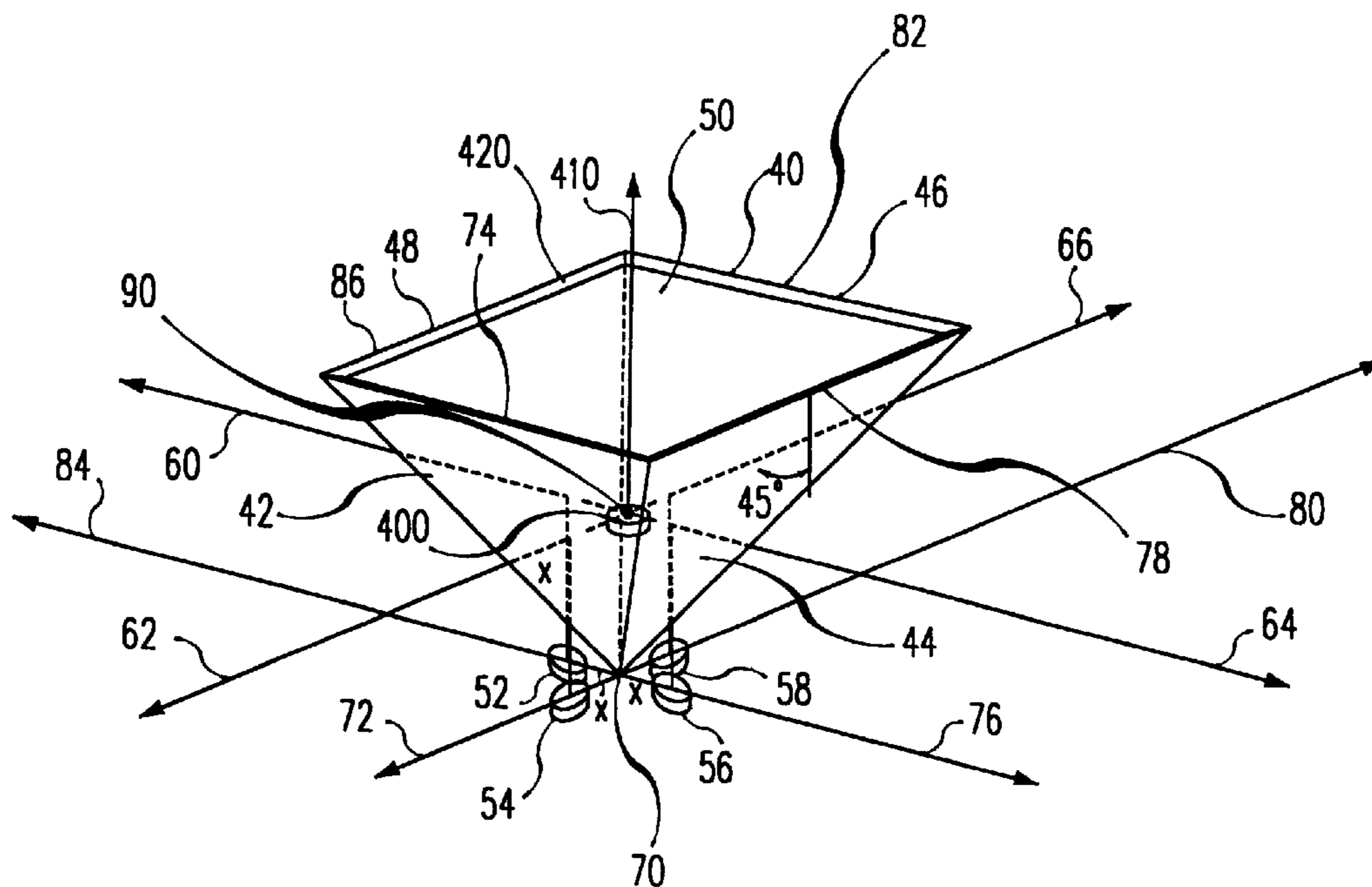

FIG. 1

PRIOR ART

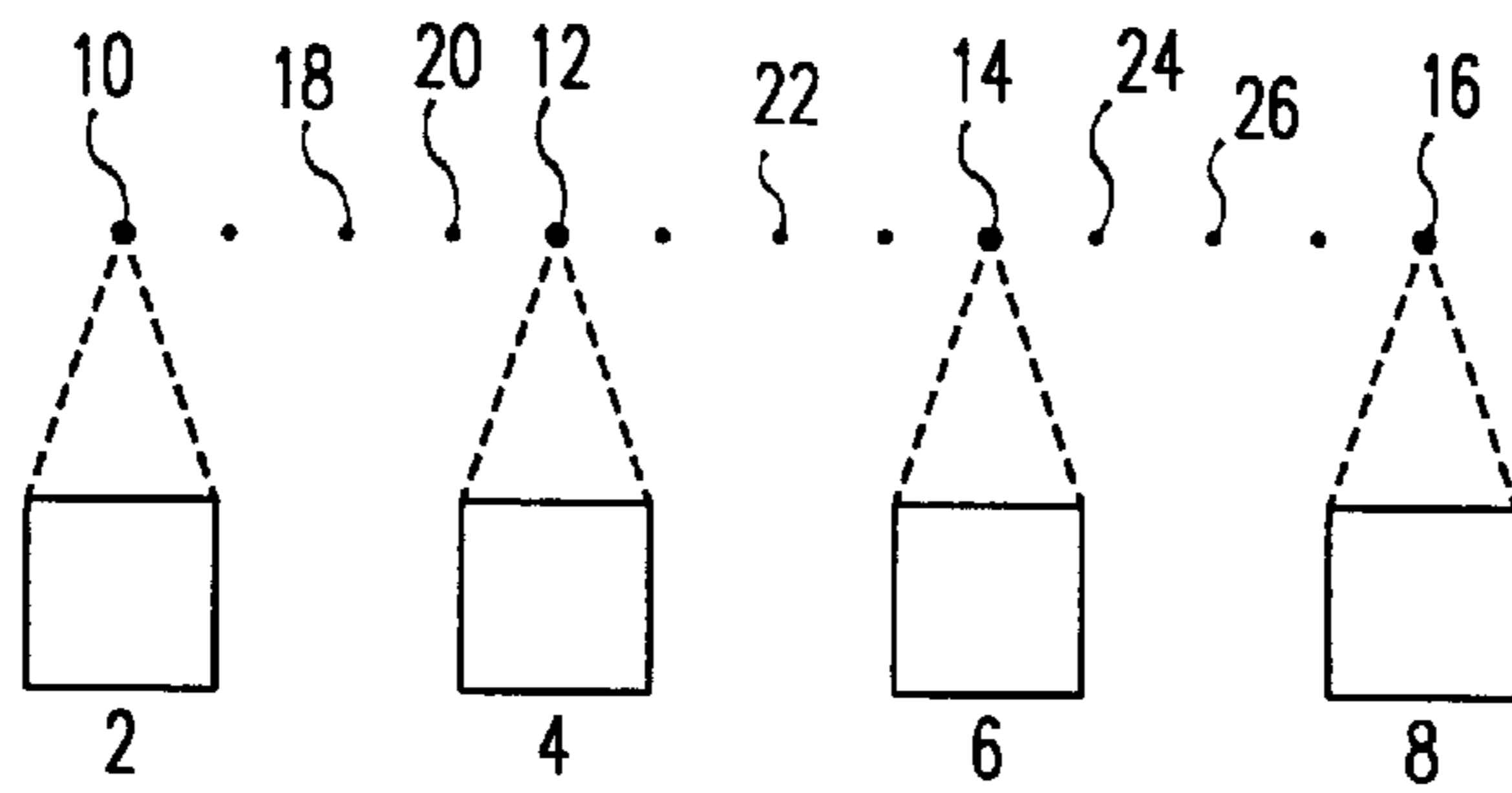

FIG. 2

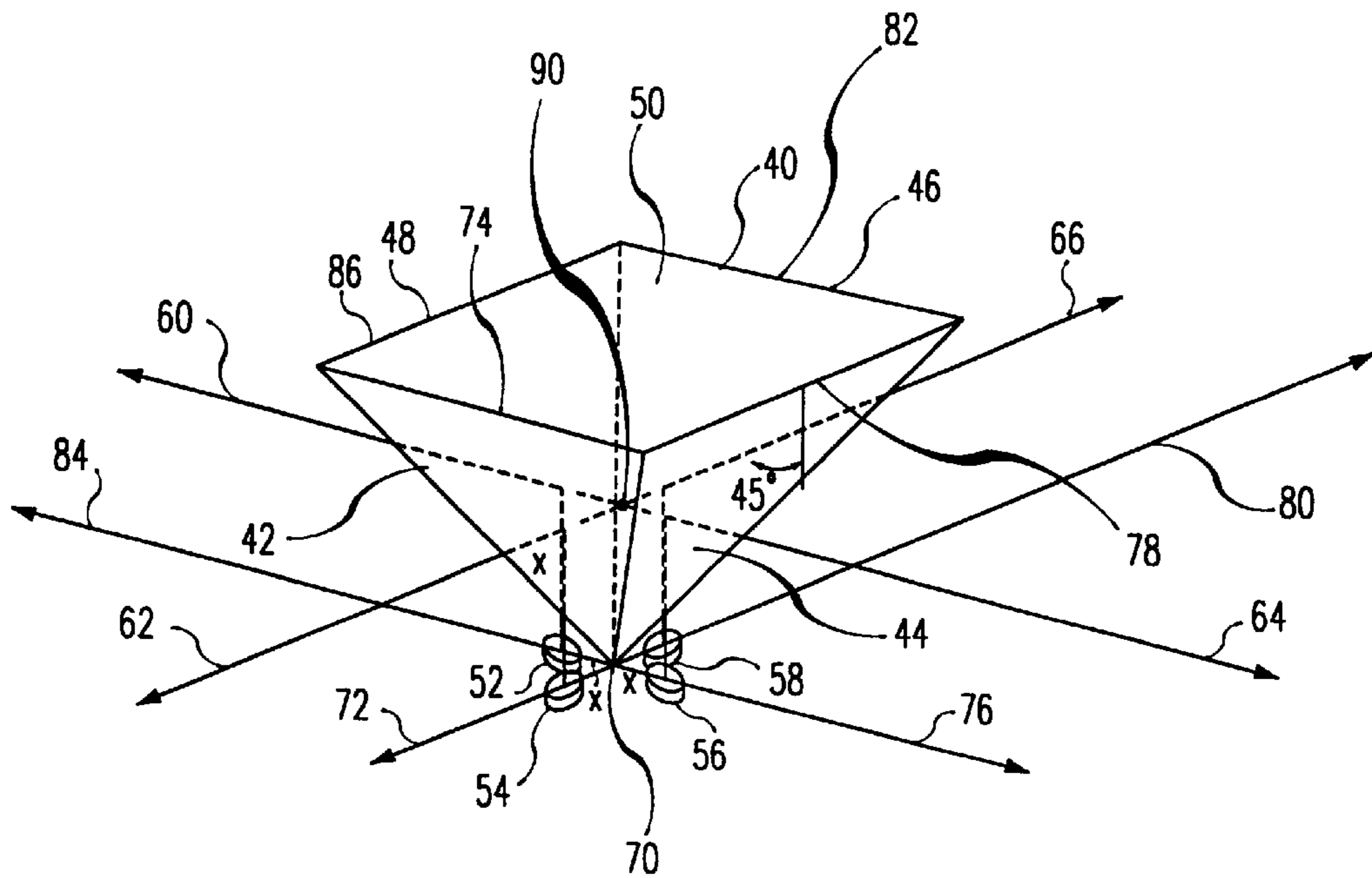

FIG. 3

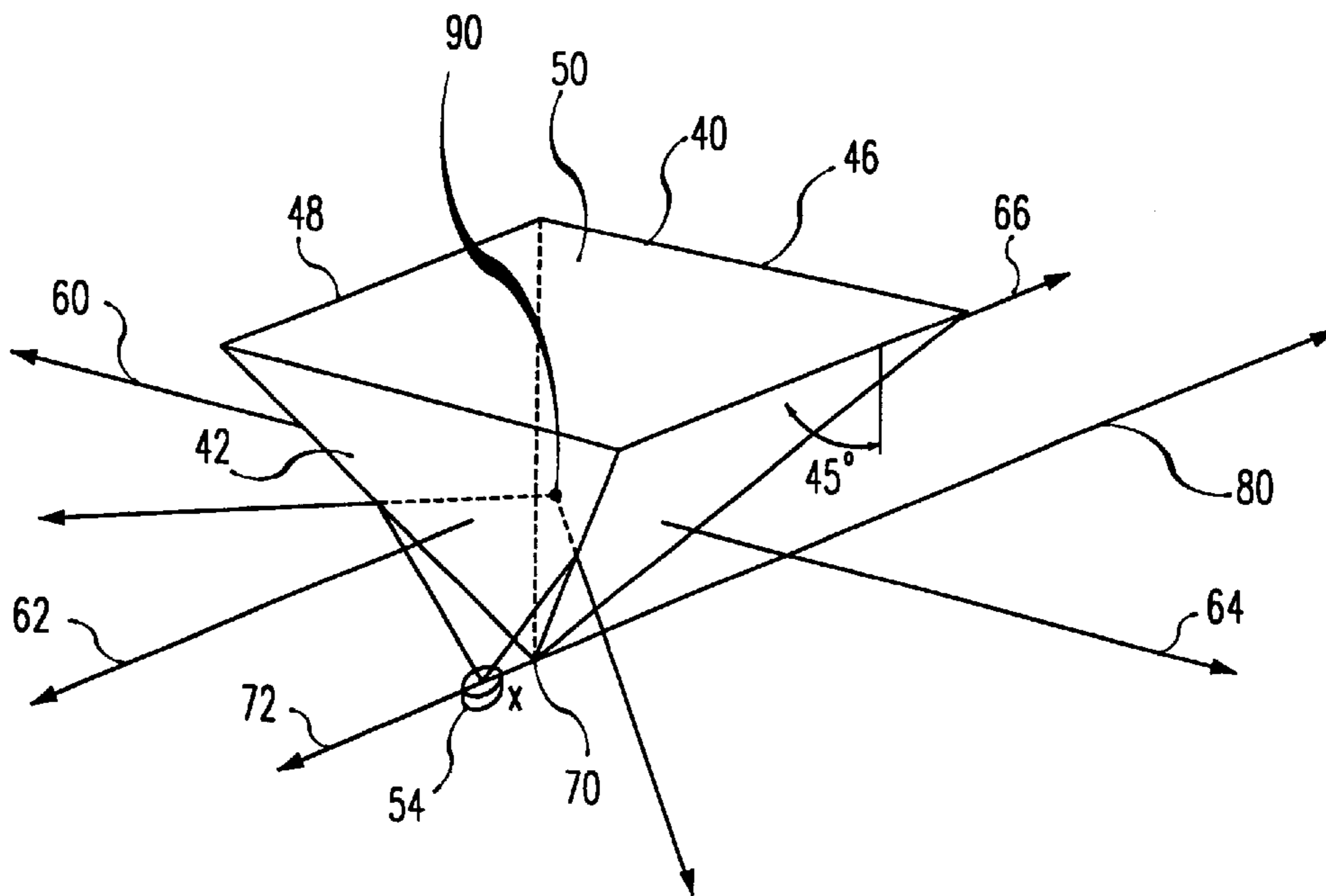

FIG. 4

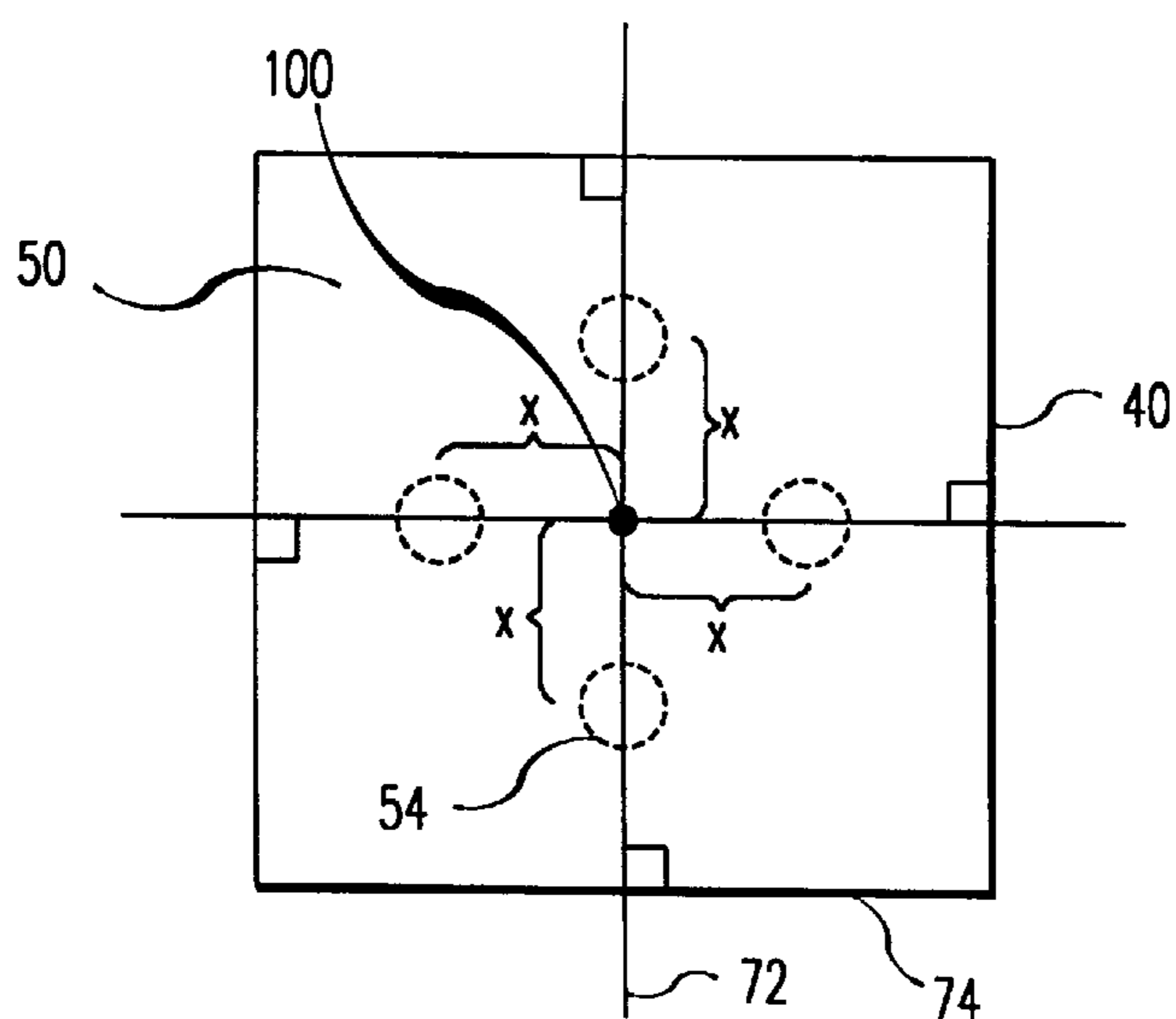

FIG. 5

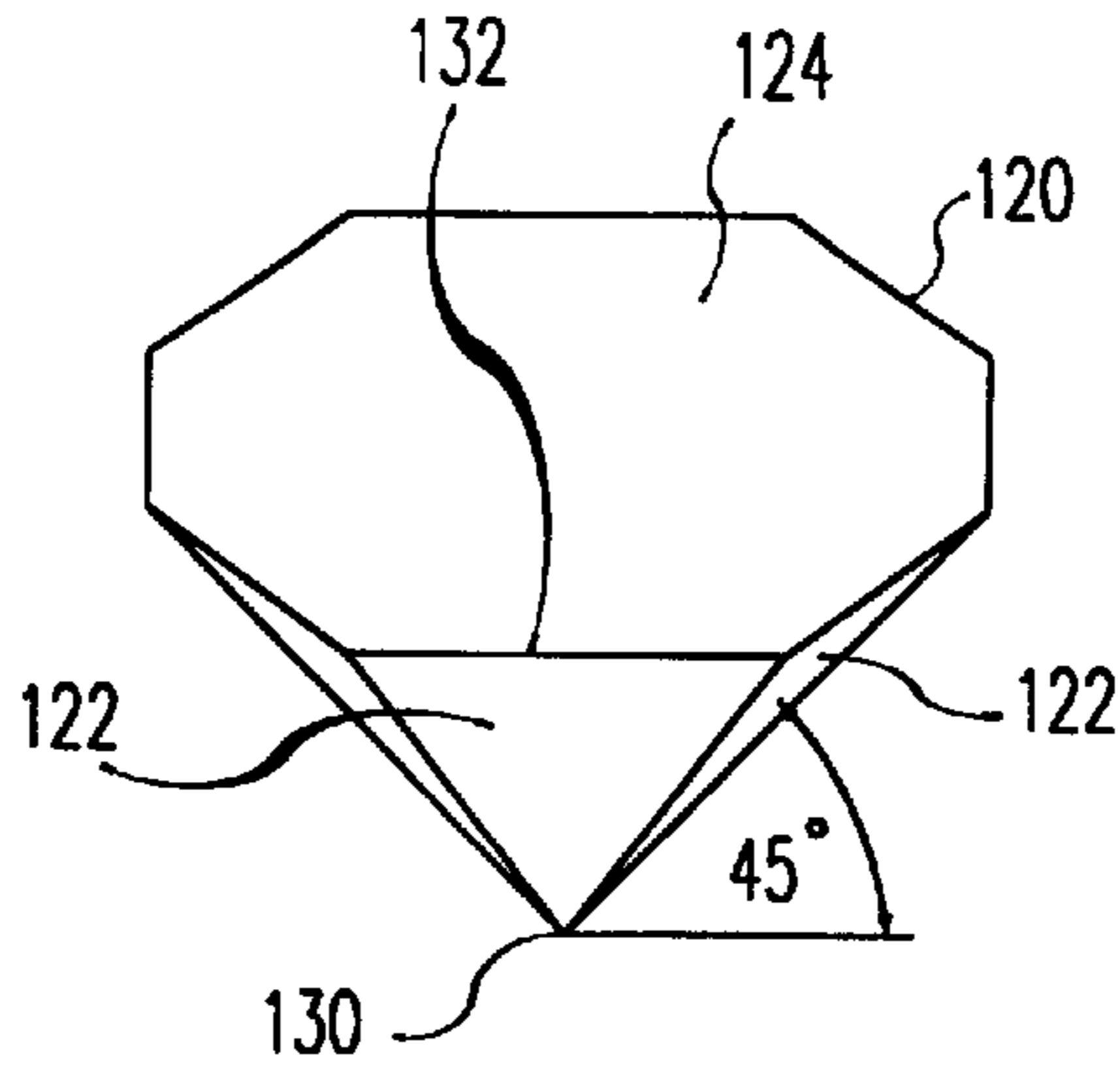

FIG. 6

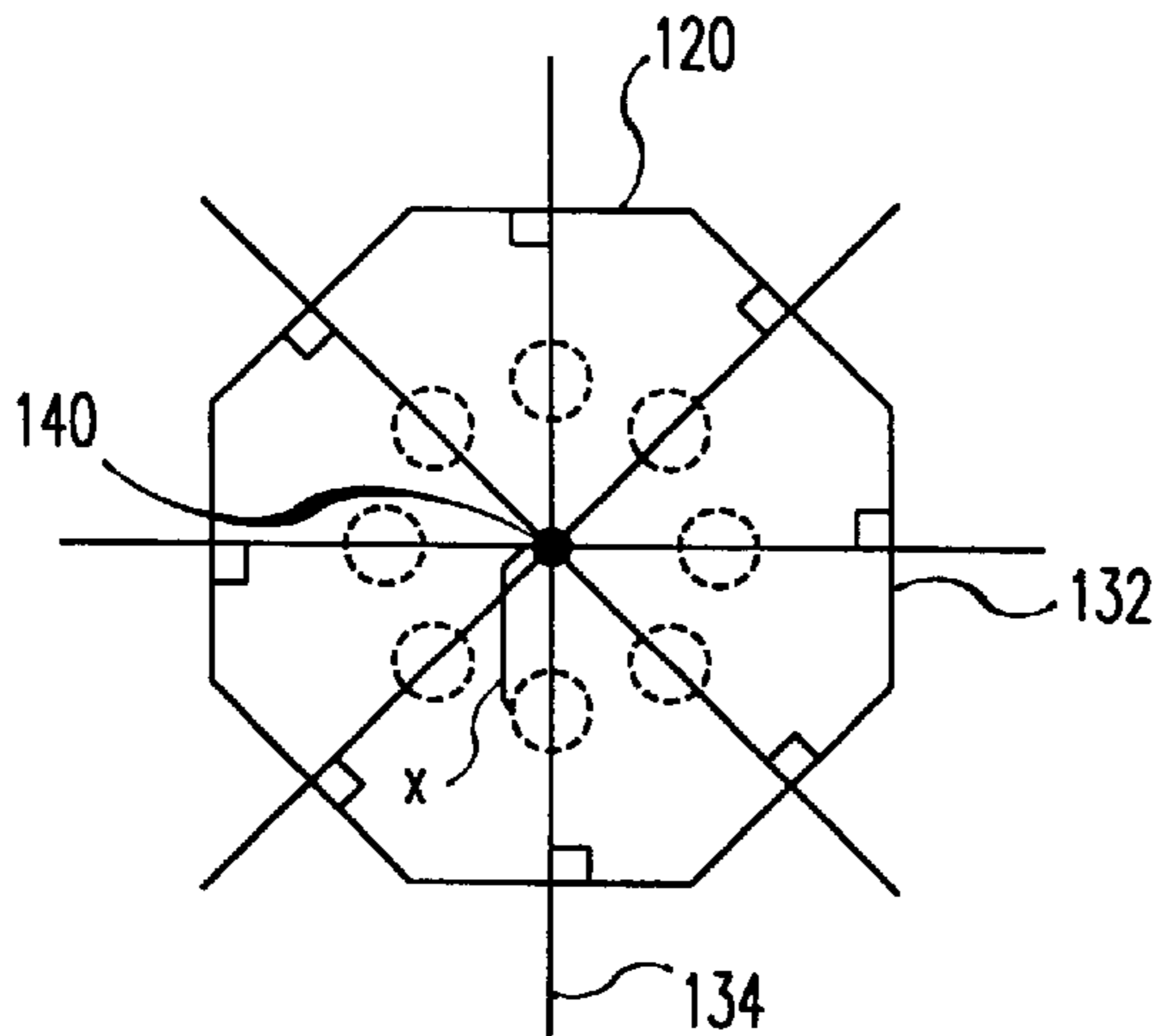

FIG. 7

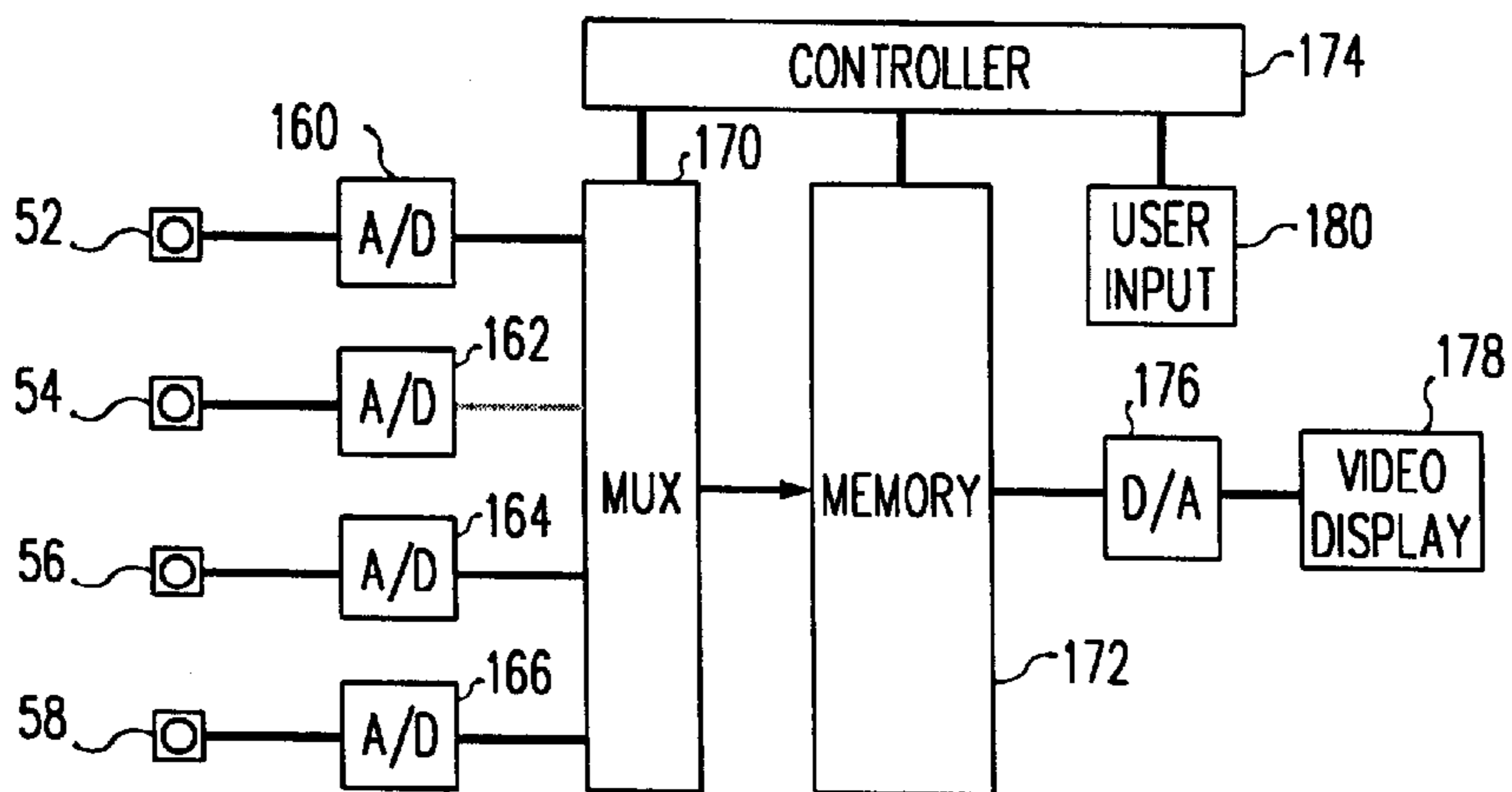

FIG. 8

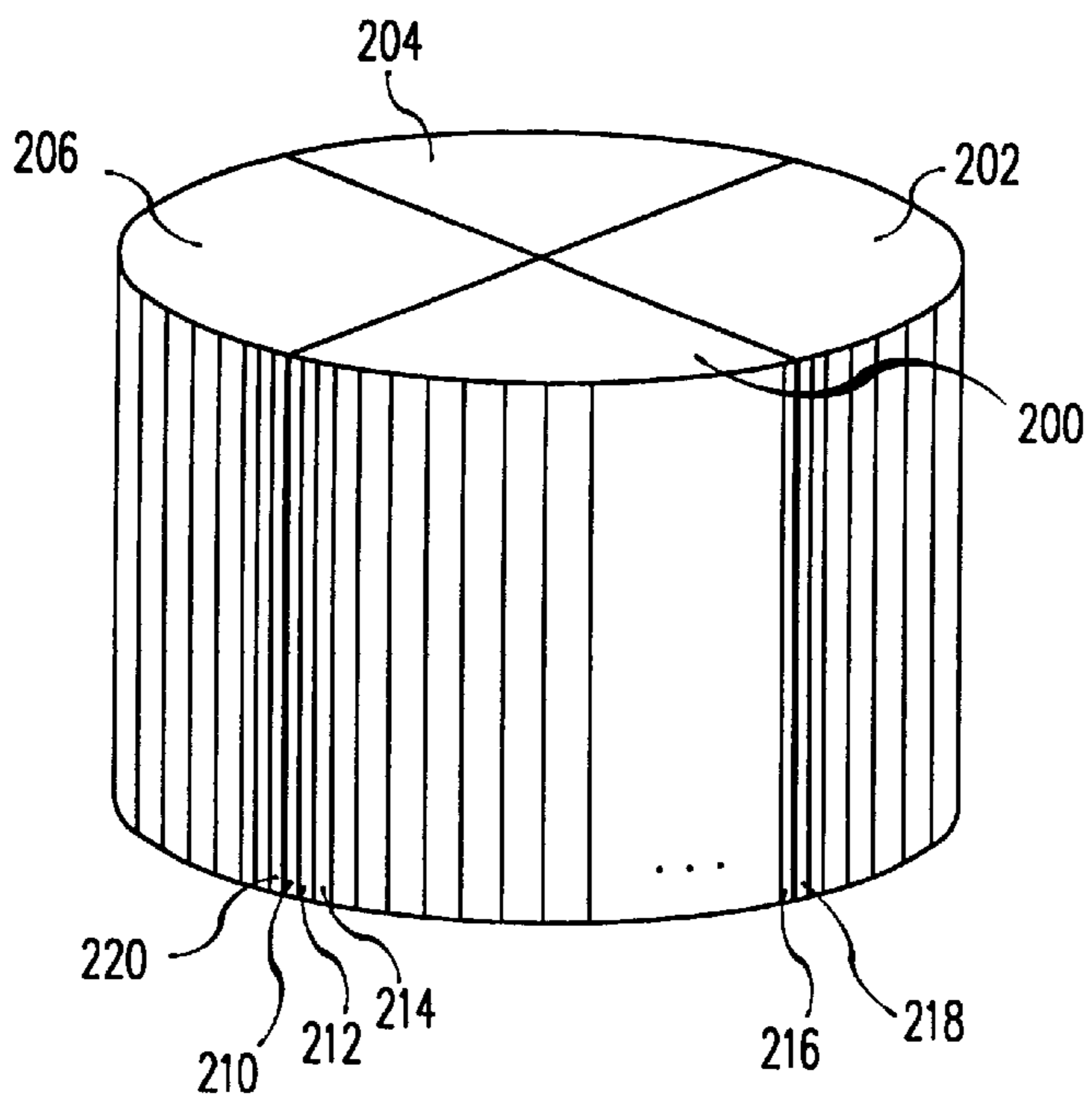

FIG. 9

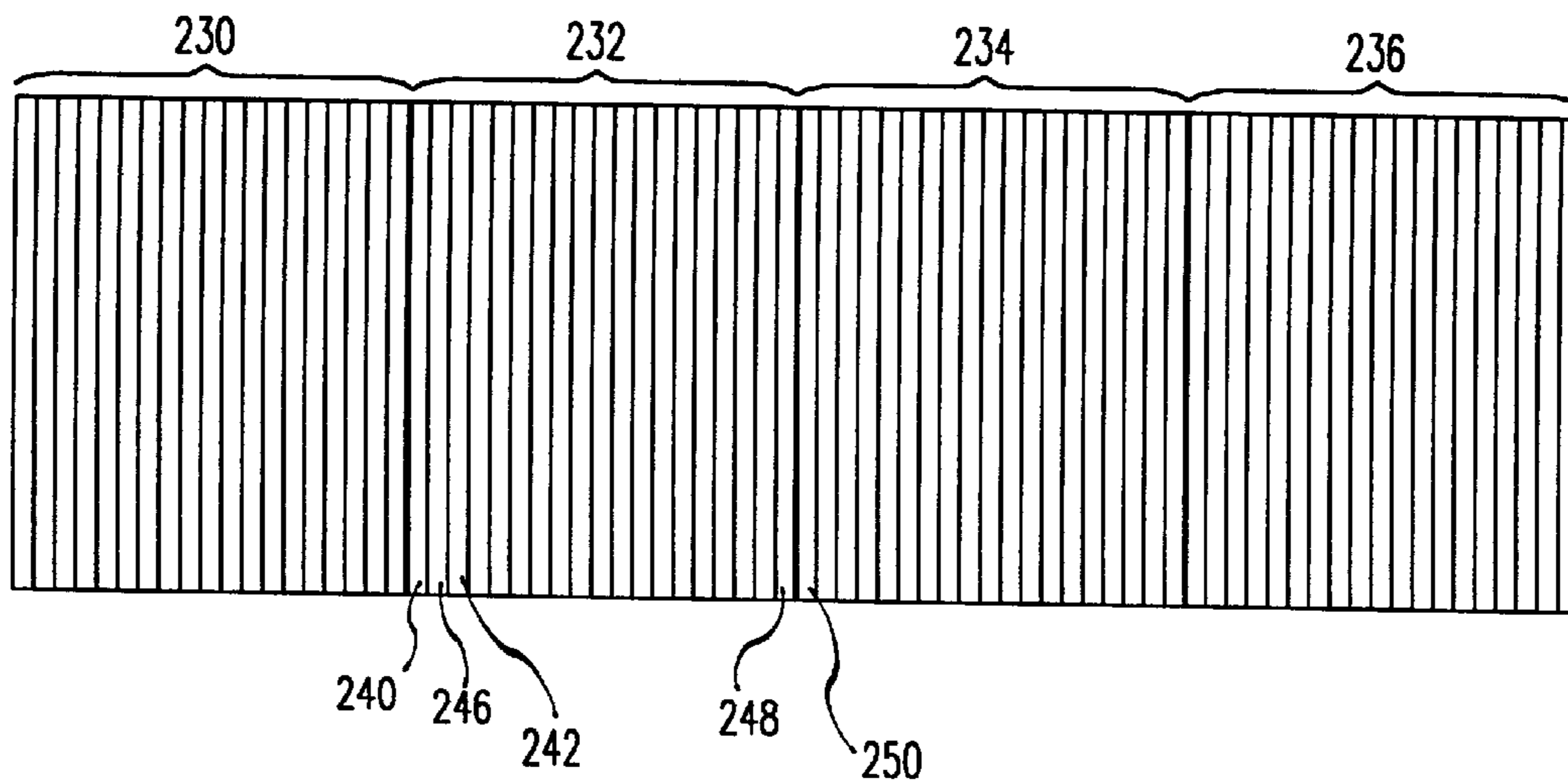

FIG. 10

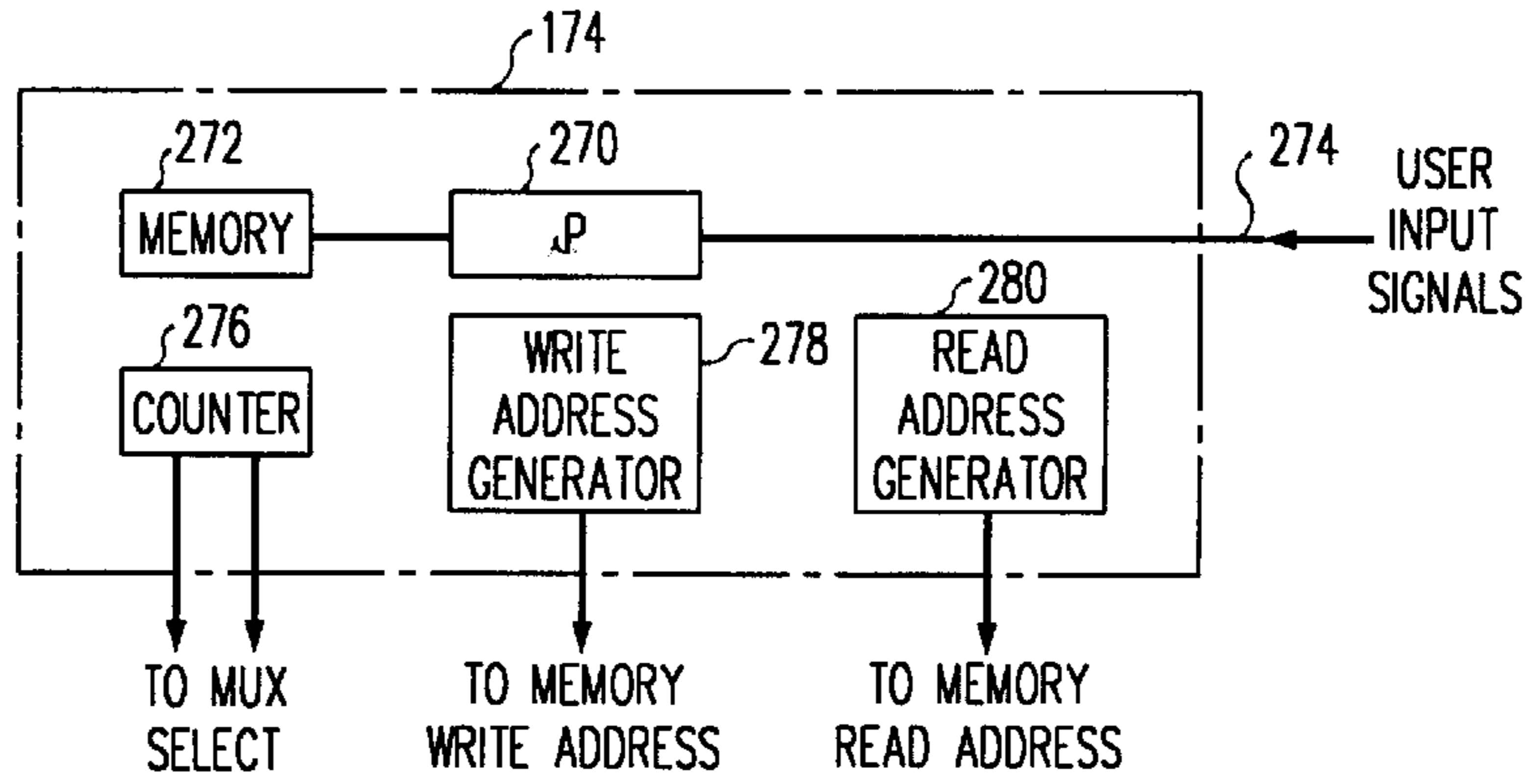

FIG. 11

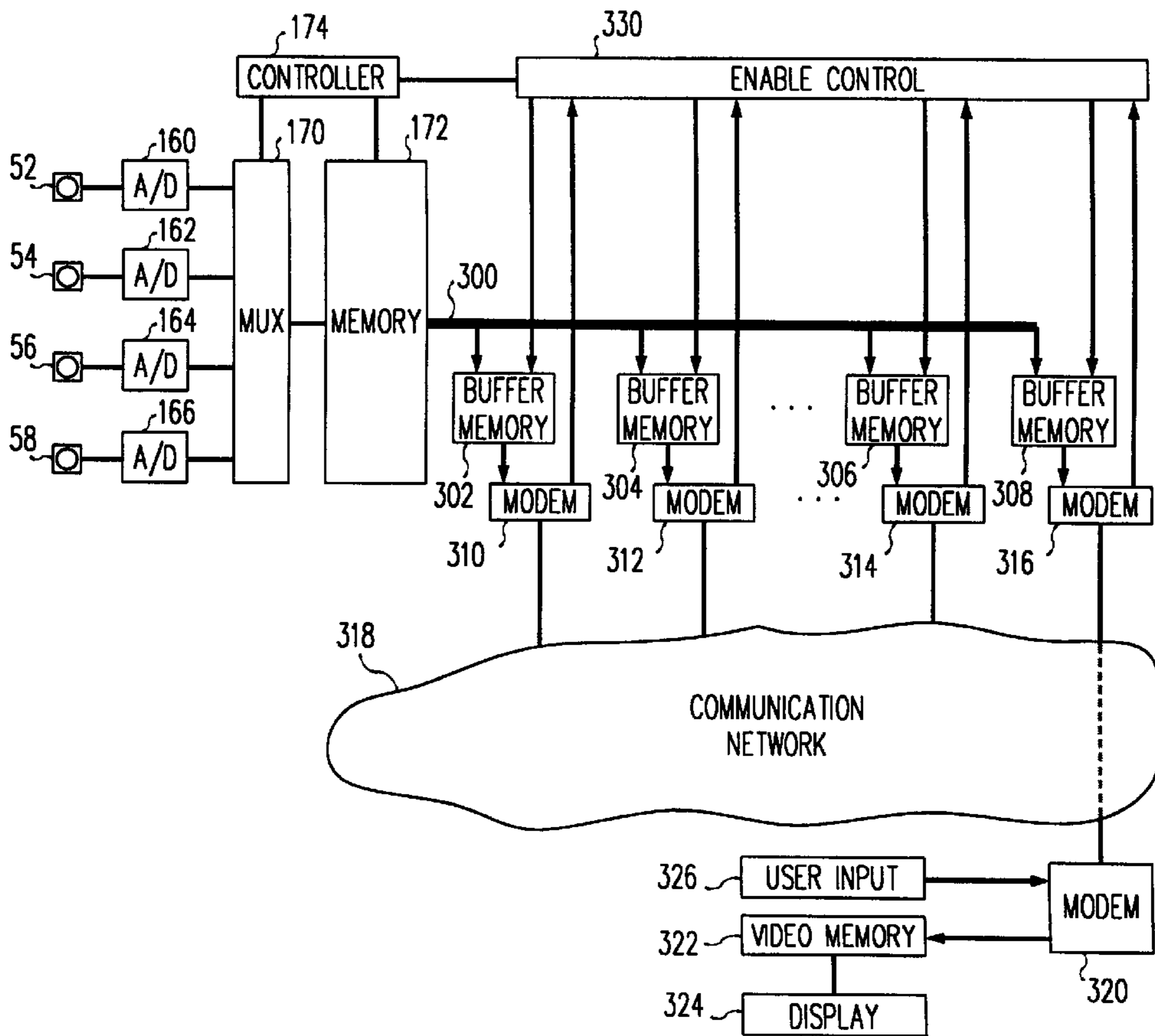

FIG. 12

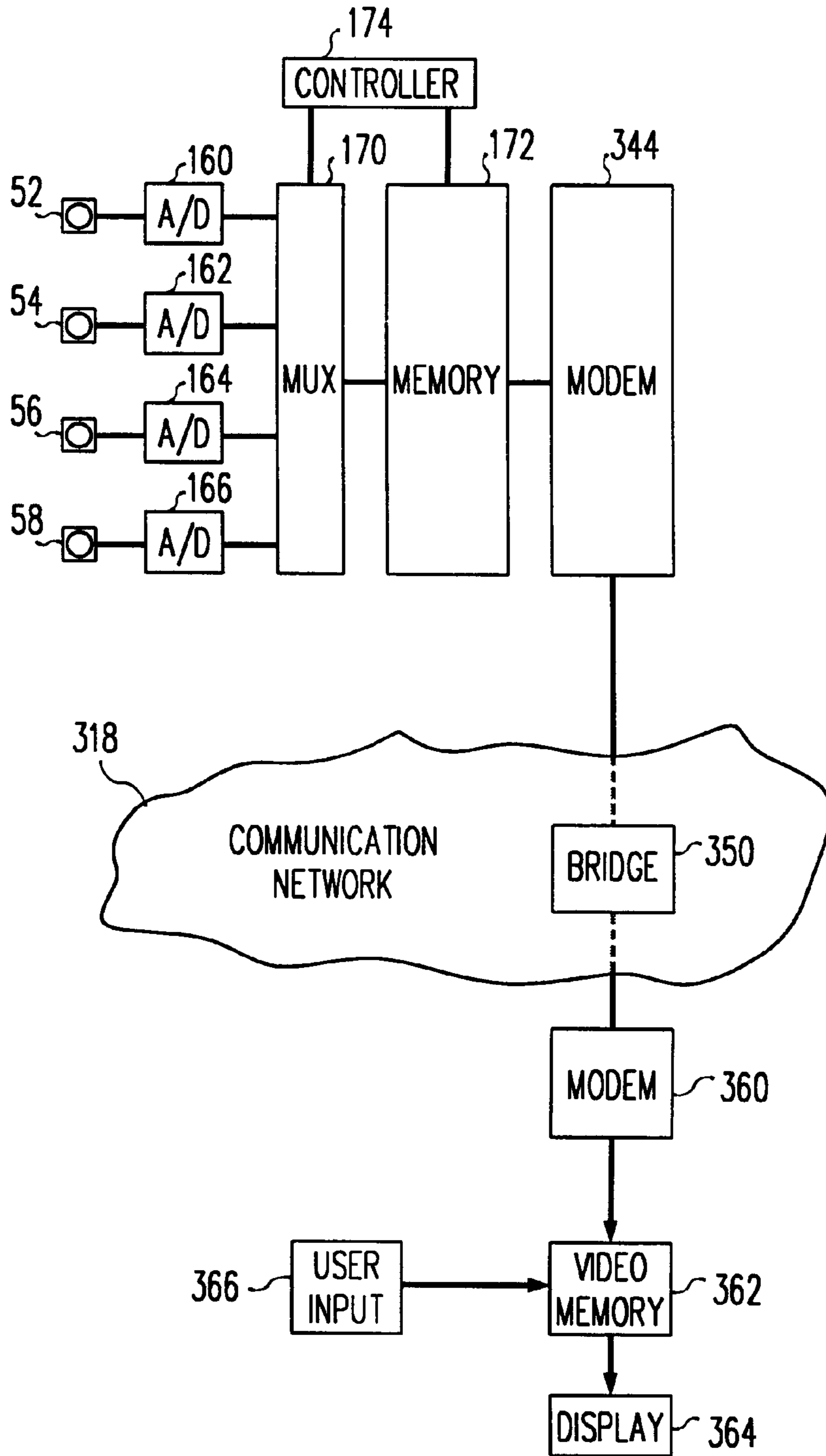

FIG. 13

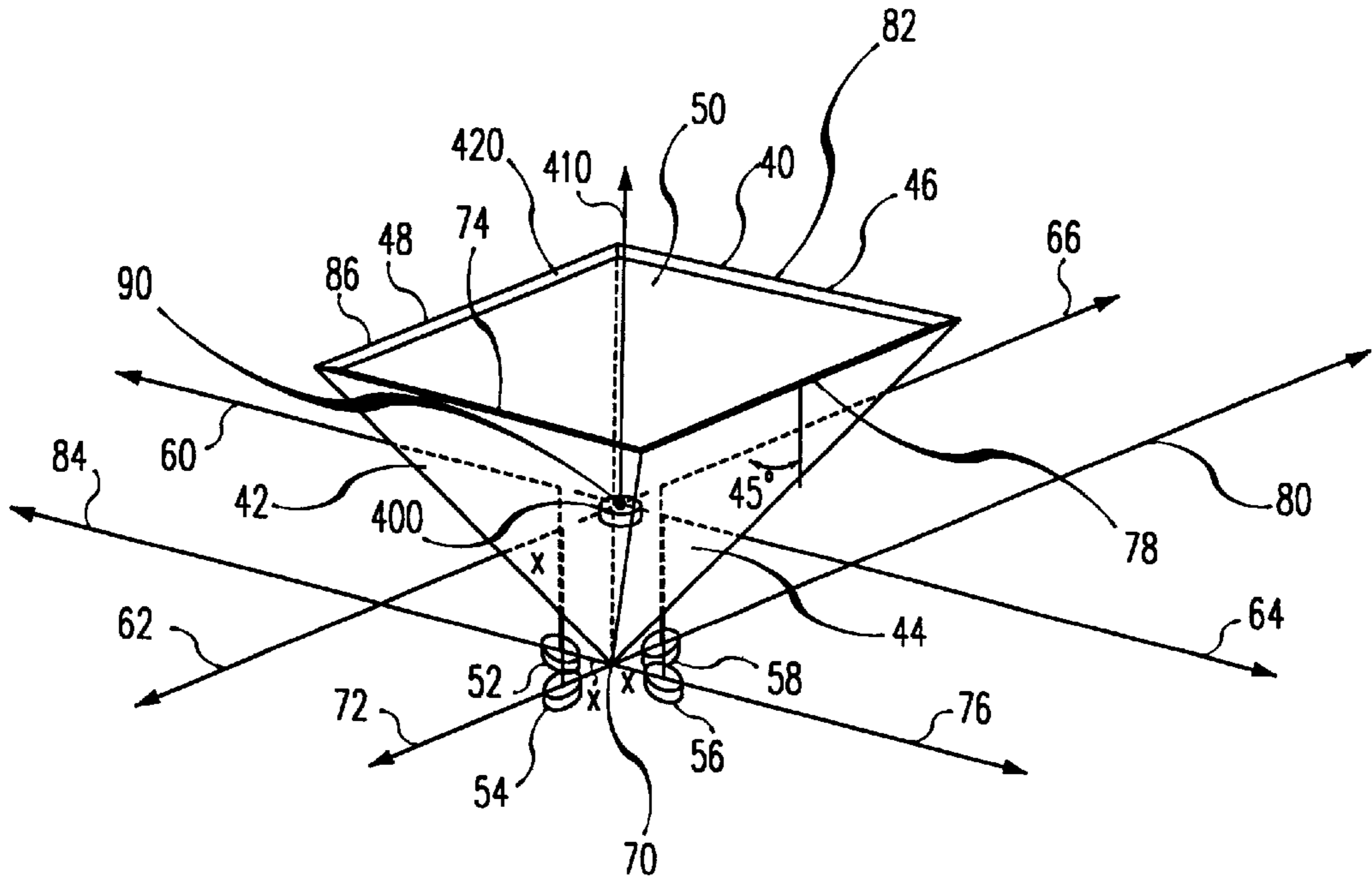

FIG. 14

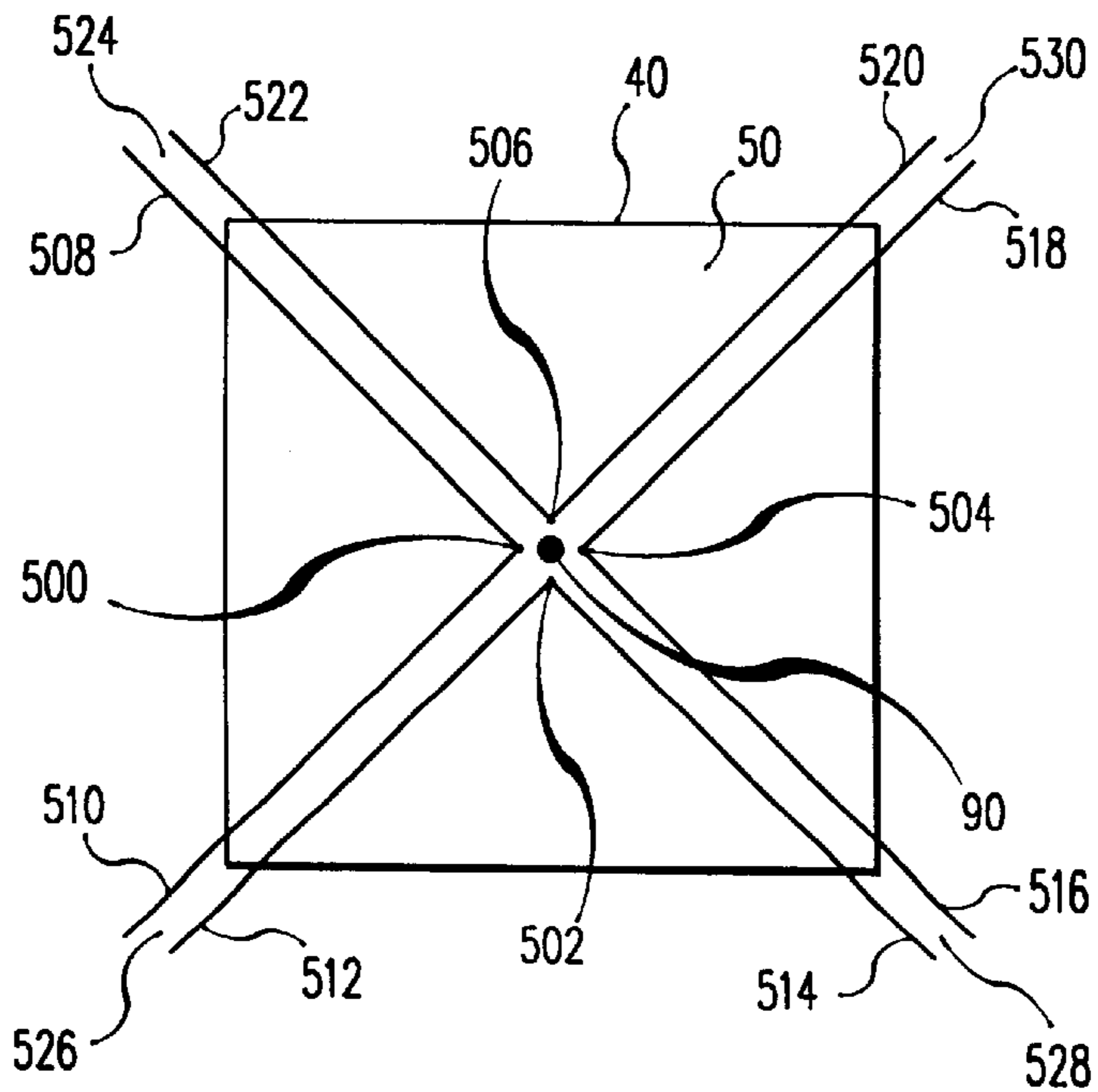
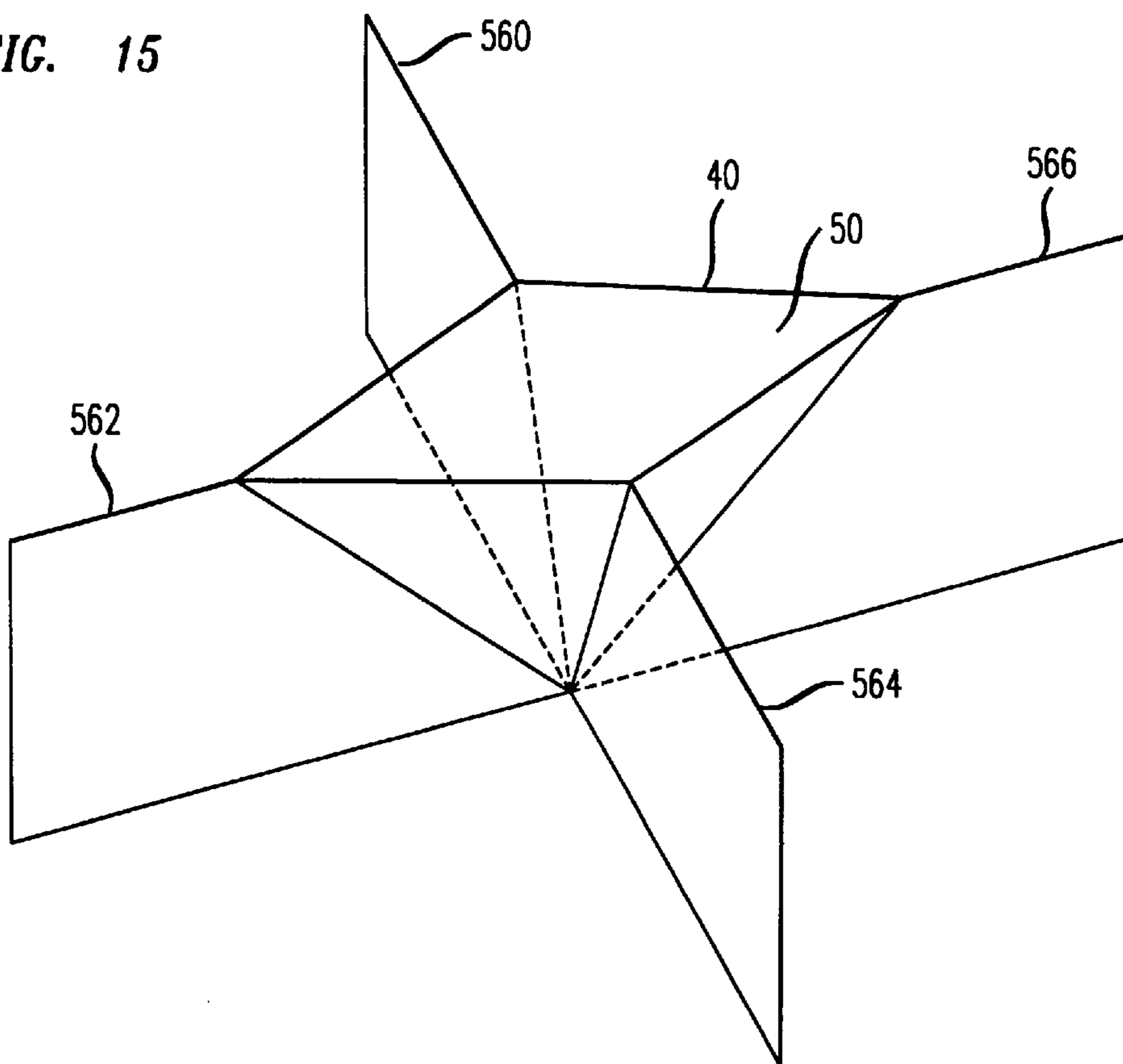

FIG. 15



PANORAMIC VIEWING SYSTEM WITH A COMPOSITE FIELD OF VIEW

CROSS REFERENCE TO RELATED APPLICATIONS

This application is a continuation of commonly assigned U.S. Patent application entitled "Panoramic Viewing System With Shades", Ser. No. 09/431,400, filed Dec. 27, 1999, which issued as U.S. Patent No. 6,356,397 on Mar. 12, 2002, which is a continuation of commonly assigned U.S. Patent application entitled "Panoramic Viewing System With Offset Virtual Optical Centers", Ser. No. 08/946,443, filed Oct. 7, 1997, which issued as U.S. Pat. No. 6,111,702 on Aug. 29, 2000, which is a continuation-in-part of commonly assigned U.S. Patent application entitled "Spherical Viewing/Projection Apparatus", Ser. No. 08/565,501 filed Nov. 30, 1995, which issued as U.S. Pat. No. 6,115,176 on Sep. 5, 2000; and is related to commonly assigned U.S. Patent Application entitled "Panoramic Viewing Apparatus", Ser. No. 08/431,356, filed Apr. 28, 1995, which issued as U.S. Pat. No. 5,745,305 on Apr. 28, 1998 and to commonly assigned U.S. Patent Application entitled "Method and System for Panoramic Viewing", Ser. No. 08/431,354, filed Apr. 28, 1995, which issued as U.S. Pat. No. 5,990,934 on Nov. 23, 1999.

BACKGROUND OF THE INVENTION

1. Field of the Invention

The present invention relates to a viewing system; more particularly, a spherical viewing system.

2. Description of the Related Art

In an effort to operate more efficiently, it is desirable to perform some tasks using telepresence. Telepresence refers to providing visual or other types of sensory information from a device at a remote site to a user that make the user feel as if he/she is present at the remote site. For example, many businesses now hold meetings using telepresence. Telepresence is also useful for distance learning and remote viewing of events such as concerts and sporting events. A more realistic telepresence is provided to a user by providing the user with the capability to switch between views, and thereby mimic, for example, looking around a meeting room.

In the past, when several views were made available to a user, several cameras with different optical centers were used. Such a situation is illustrated in FIG. 1. FIG. 1 illustrates cameras **2**, **4**, **6** and **8** with optical centers **10**, **12**, **14**, and **16**, respectively. When the user decided to change views, he or she simply switched between cameras. In more sophisticated systems, when a user decided to change views, he or she was able to obtain a view from optical centers **10**, **12**, **14**, or **16** as well as from additional optical centers **18**, **20**, **22**, **24** or **26**. Views associated with optical centers such as **18**, **20**, **22**, **24**, and **26** were obtained by using views from the two cameras nearest to the selected optical center. For example, a view from optical center **18** was obtained by using the views from cameras **2** and **4** and interpolating between the two views so as to simulate a view from optical center **18**. Such procedures introduced irregularities into views. In addition, forming these interpolated views required a large amount of computational power and time, and thereby made this technique expensive and slow to respond to a user's commands. This computational overhead also limited the number of users that can simultaneously use the system.

Other prior art discloses that the several views made available to a user can also be derived from a single

wide-angle view that is created from multiple individual views captured by multiple distinct cameras. However, prior-art arrangements to create a single wide-angle view from multiple individual views have been unsatisfactory. In some arrangements, there is substantial parallax between the individual views, parallax that would lead to artifacts where the individual views would overlap or adjoin in any composite image; such artifacts are avoided in some cases by intentionally fragmenting the wide-angle view to have substantial gaps between individual images upon their display (e.g., U.S. Pat. No. 2,942,516). In some other arrangements, even though parallax between individual views may be minimal or absent, image artifacts remain and there is no suggestion on how to prevent these image artifacts from occurring where individual views would adjoin in any composite image (e.g., U.S. Pat. Nos. 3,118,340, 3,356,002, 4,890,314, 5,187,571). In some other arrangements, the number of individual cameras is limited to be no more than three and precise optical alignment of cameras and projectors is required to create a composite wide-angle image that is optical, rather than electronic, for all practical purposes precluding the use of such a composite image in providing multiple views to a user as described above (e.g., U.S. Pat. Nos. 2,931,267, 3,031,920, 4,890,314). Of particular relevance here are prior-art arrangements that use one or more mirrors with more than one camera to create a wide-angle composite image: One problem that has remained unaddressed in such arrangements is how to rid the composite image of image artifacts due to portions of individual images being captured off edges of mirrors (e.g., U.S. Pat. Nos. 2,931,267, 3,031,920, 3,118,340, 4,890,314, 5,187,571); further, even in those of such arrangements in which an attempt is made to reduce other image artifacts, which occur due to causes other than reflection off edges of mirrors and occur where individual images come together in a composite image, the arrangements and techniques proposed are limited to using no more than three cameras and are purely optical rather than electronic, requiring precise optical alignment of cameras and projectors and not lending themselves to providing multiple views to a user as described above (e.g., U.S. Pat. Nos. 2,931,267, 3,031,920). Some other prior art devices have no particular advantage with respect to acquiring a wide-angle field of view and also fail to avoid the above-mentioned image artifacts caused by portions of individual images being captured off edges of mirrors (e.g., U.S. Pat. Nos. 5,016,109, 5,194,959). These are just some of the drawbacks of the prior art that prevent it from being used to create high-quality composite wide-angle images that can be used to provide multiple views to a user as described above.

SUMMARY OF THE INVENTION

One embodiment of the present invention provides an omnidirectional or panoramic viewer where several cameras have a common optical center. The cameras are positioned so that they each view a different reflective surface of a polyhedron such as a pyramid. This results in each camera having a virtual optical center positioned within the pyramid. The field of view of each of the cameras is merged with the individual fields of view of the other cameras and arranged to form a composite field of view which is a continuous 360 degree view of an area when taken as a whole. The user can sweep through 360 degrees of viewing, where each view has the same or nearly the same optical center, by simply using the output of one camera or the combination of two cameras without requiring the computational overhead of interpolation used in the prior art. Such

an arrangement may be used to enhance use of virtual meeting rooms by allowing a viewer to see the meeting room in a more natural format. This format corresponds closely to a person sitting in the actual meeting who simply turns his or her head to change the view at a particular time.

In another embodiment of the present invention, a nearly spherical view is provided to a user by placing a camera with its optical center at the common virtual optical center of the viewer. In order to enhance the spherical view, the camera at the common virtual optical center may use a wide angle lens.

In still another embodiment of the invention, the cameras are positioned so that their effective optical centers are offset from each other. The offsets produce narrow blind regions that remove image distortions received from the edges of the pyramid's reflective surfaces. Additionally, planar shades that extend in an outward direction are positioned in the blind regions.

In yet another embodiment of the present invention, the viewing device may include any type of image transducer or processing device. If the image transducer or processing device is a camera or other type of image capture device, a panoramic or spherical image is captured for the user, and if the image transducer or processing device is a projector or other type of image producing device, a panoramic or spherical image is produced for the user.

BRIEF DESCRIPTION OF THE DRAWING

FIG. 1 illustrates a prior art multiple camera viewing system;

FIG. 2 illustrates a four camera omnidirectional or panoramic viewing system using a four-sided pyramid with reflective surfaces;

FIG. 3 illustrates how a reflective surface of the pyramid is used to provide each camera with a common optical center;

FIG. 4 illustrates the top view of the pyramid illustrating the camera positions;

FIG. 5 illustrates an eight-sided pyramid with reflective side surfaces;

FIG. 6 is a top view of the pyramid of FIG. 5;

FIG. 7 is a block diagram of a system to control data produced by the cameras;

FIG. 8 illustrates the association between the data received from the cameras and the view presented to a user;

FIG. 9 illustrates an addressing scheme for the memory of FIG. 7;

FIG. 10 is a block diagram of the controller of FIG. 7;

FIG. 11 illustrates using a telecommunications network to provide a selection of views to a plurality of users;

FIG. 12 illustrates a second embodiment for providing a selection of views to multiple users over a telecommunications network;

FIG. 13 illustrates the viewing system of FIG. 2 with a fifth camera;

FIG. 14 illustrates a top view of the pyramid of FIG. 2 with displaced virtual optical centers; and

FIG. 15 illustrates the pyramid of FIG. 14 with shades positioned in blind regions.

DESCRIPTION OF THE PREFERRED EMBODIMENT

FIG. 2 illustrates a four camera system for providing a 360 degree view to a user, where the cameras each have a

common virtual optical center within the pyramid. Pyramid 40 has reflective sides 42, 44, 46 and 48 and may be a hollow or solid structure. In a preferred embodiment, each of the reflective sides forms a 45 degree angle with a plane parallel to base 50 and passing through the vertex of pyramid 40. Cameras 52, 54, 56 and 58 are associated with pyramid reflective surfaces 48, 42, 44, and 46, respectively. The cameras may be image gathering devices such as an optical scanner. As a result, camera 52 views a reflection from surface 48 to enable it to view objects in the direction of arrow 60. Camera 54 views a reflection from surface 42 to view objects in the direction of arrow 62. Camera 56 views a reflection from surface 44 to view objects in the direction of arrow 64, and camera 58 views a reflection from surface 46 to view objects in the direction of arrow 66. Each camera has a 90 degree field of view. The combination of the four cameras viewing reflections from their associated reflective surfaces on pyramid 40, produce a 360 degree view of the area surrounding pyramid 40. It is desirable to locate the optical center of each camera on a plane that is parallel to base 50 and intersects vertex 70 of pyramid 40. Each camera's optical center should also be located on a line that passes through vertex 70 and is perpendicular to the base line of the camera's associated reflective surface. For example, the optical center of camera 54 is located on line 72. Line 72 is perpendicular to base line 74 of reflective surface 42. Line 72 is in a plane that passes through vertex 70 and is parallel to base 50. Likewise, the optical center of camera 56 is positioned on line 76 which is perpendicular to baseline 78, the optical center of camera 58 is positioned on line 80 which is perpendicular to base line 82, and the optical center of camera 52 is positioned on base line 84 which is perpendicular to base line 86.

Each camera optical center is positioned on one of the above described lines at a distance X from vertex 70 and each camera has its optical axes or direction of view pointing perpendicular to base 50. (The distance X should be such that the reflective surface reflects as much of the camera's field of view as desired; however, the defects in the reflective surface become more visible when the camera is moved closer to the reflective surface.) This positioning of optical centers results in the cameras sharing a virtual optical center located at position 90. Virtual optical center 90 is located a distance X from the vertex 70 on a line that passes through vertex 70 and is perpendicular to base 50.

FIG. 3 illustrates another view of pyramid 40 where only camera 54 is shown for the sake of simplicity. Camera 54 is positioned on line 72 so as to have a virtual optical center at position 90 within pyramid 40. If camera 54 has a 90 degree field of view in the direction perpendicular to base 50, and if the optical center of camera 54 is at a distance of X from vertex 70 along line 72, camera 54 has a 90 degree view in the direction of arrow 62. In similar fashion, cameras 56, 58, and 52 have 90 degree views in the direction of arrows 64, 66, and 60, respectively. This arrangement inexpensively produces a 360 degree field of view of an area because cameras with a 90 degree field of view have relatively inexpensive optics.

FIG. 4 is a top view of pyramid 40. FIG. 4 illustrates the placement of the optical center of camera 54 along line 72. Line 72 should be in a plane that passes through vertex 70 and is parallel to base 50. The line should also be perpendicular to base line 74 of pyramid 40. The camera's optical center should be positioned a distance X from vertex 70 along line 72. The distance X should be such that the reflective surface reflects as much of the camera's field of view as desired. Point 100 is located on base 50 at a position

where a line from vertex **70** perpendicularly intersects base **50**. In a similar fashion, the optical centers of cameras **56**, **58** and **52** are positioned the distance X along lines **76**, **80** and **84**, respectively.

FIG. **5** illustrates an eight-sided pyramid **120**. Pyramid **120** has reflective surfaces **122** where each of surfaces **122** forms a 45 degree angle with a plane that passes through vertex **130** and is parallel to base **124**. As with the four-sided pyramid of FIG. **2**, each reflective surface of FIG. **5** may have a camera associated with it. Each camera's optical center is positioned on a line that is in a plane that passes through vertex **130** and is parallel to base **124**. The line is perpendicular to base line **132** of the reflective surface associated with the camera to be positioned. Using an eight-sided pyramid offers the advantage of using cameras with only a 45 degree field of view to obtain a 360 degree view. Cameras with only a 45 degree field of view have inexpensive optics and enable a 360 degree view to be constructed using relatively inexpensive components.

FIG. **6** is a top view of pyramid **120**. As discussed with regard to FIG. **5**, each camera's optical center is positioned along a line **134** which is in a plane that passes through vertex **130** and is parallel to base **124**. The optical centers are positioned a distance X along line **134** which is perpendicular to the appropriate base line **132**. Point **140** is on base **124** at the point of intersection between base **124** and a line that passes through vertex **130** and is perpendicular to base **124**.

Pyramids having more or less reflective sides may be used. The advantage of using pyramids having a large number of sides is that cameras with moderate to small fields of view may be used. Cameras with moderate fields of view have relatively inexpensive optics. The number of sides used in a pyramid is somewhat limited by the cost of providing a large number of cameras. A 360 degree view of a scene may be provided using a pyramid having three reflective sides. It may be expensive to use only a three-sided pyramid in order to provide a 360 degree field of view. This embodiment of the invention uses three cameras each with a 120 degree field of view, and cameras with such a wide field of view use relatively expensive optical components.

In applications where a full 360 degree view is not desired, it is possible to build a viewer that does not have a camera associated with each reflective surface of the pyramid.

FIG. **7** illustrates a block diagram of a system for controlling data produced by the cameras of a viewing device such as the viewing device described in FIGS. **2** through **4**. Cameras **52**, **54**, **56** and **58** obtain a 360 degree view of an area via their associated reflective surfaces of pyramid **40**. The image signal or output signal of cameras **52**, **54**, **56** and **58** are passed through analog to digital converters (A/D) **160**, **162**, **164**, and **166**, respectively. The output of the cameras can be thought of as a stream of pixels and the output of the A/Ds can be thought of as data representative of the pixels from the cameras. The output of the A/Ds are passed through mux **170**. Mux **170** allows the pixel data from each of the A/Ds to reach memory **172**. Controller **174** cycles the select lines of mux **170** so that the outputs of all of the A/Ds are stored in memory **172**. Mux **170** is switched at a rate that is four times the pixel rate of the cameras. If more or less cameras are used, the rate at which mux **170** is switched will be increased or slowed accordingly. It is also possible to eliminate mux **170** and to store the output of each A/D in a separate memory. Controller **174** is implemented using a microprocessor which provides control signals to counters that control the switching of mux **170** and counters

used to provide addressing to memory **172**. The control signals to the counters include reset, enable and a starting offset.

As a result of the pixel information being passed to memory **172**, memory **172** contains a 360 degree view of a scene. Pixel information stored in memory **172** is passed through digital to analog converter (D/A) **176** and to video display **178**. The actual portion of memory **172** that is passed to video display **178** via D/A **176** is controlled via user input device **180**. User input device **180** may be a common device such as a mouse, joystick, or keyboard. The user may simply lean a joystick to the right to shift his view to the right, lean the joystick to the left to shift the view to the left, or leave the joystick in the center to keep the view unchanged. Based on the input from user device **180**, controller **174** varies offsets and starting addresses that are used to provide addressing to memory **172**.

FIG. **8** illustrates the relationship between the data provided by the cameras and the view available to the user. Since the cameras share a virtual optical center, the view can be thought of as a cylindrical view. Sector **200** can be thought of as representing the information provided by camera **52**, sector **202** can be thought of as representing the information provided by camera **54**, sector **204** can be thought of as representing the information provided by camera **56**, and sector **206** can be thought of as representing the information provided by camera **58**. The surface of the cylinder in each sector can be thought of as a collection of columns, where each column is composed of pixels. For example, sector **200** can be thought of as a collection of columns including columns **210**, **212**, **214** and **216**. Likewise, the output produced by camera **54** can be thought of as a collection of columns which include column **218** in sector **202** and the output of camera **58** can include columns such as column **220** in sector **206**. The column of pixels near the sector boundaries are closer together than the columns near the center of a sector. This occurs because the cameras capture the image on a plane while FIG. **8** shows the columns projected onto a cylindrical surface.

FIG. **9** illustrates how memory **172** is divided to provide easy access to different views based on signals from user input device **180**. Sections **230**, **232**, **234** and **236** correspond to sectors **206**, **200**, **202** and **204**, respectively. Each of sections **230**, **232**, **234** and **236** can be thought of as a block within memory **172**. The blocks in memory **172** are broken into columns of sequential addresses. The first column of memory segment **230** corresponds to the first column of pixels of sector **206**. The number of memory positions associated with a column should be at least sufficient to have one location for each pixel in a particular column. For example, if a column of pixels from FIG. **8** includes 1000 pixels, each column associated with the memory segments of FIG. **9** should have at least 1000 locations. The number of columns associated with a particular memory segment should be at least equal to the number of columns associated with a particular section of the cylinder of FIG. **8**.

If a camera scans in a horizontal direction, sequential pixels are written in adjacent columns, but possibly different rows, of a particular memory segment by simply changing an offset to a counter generated address. The overall write address is generated by adding the offset to the counter's output. This offset is changed at the rate in which the horizontally scanned pixels are received. After a horizontal scan is completed, the counter is incremented and once again the offsets are changed at the horizontal scan rate. As a result, when addressing a particular segment of memory during a write cycle, the columns are addressed by changing

the offset at the horizontal pixel scan rate, and incrementing the counter at the vertical scan rate. This type of addressing scheme is used for accessing columns within each memory segment. When addressing different memory segments during a write cycle, a write segment offset is added to the sum of the counter output and the column offset. The write segment offset permits addressing memory segments **230**, **232**, **234**, and **236**. The segment offset is changed at the same rate as mux **170** is switched.

Pixel data is read from memory **172** in a similar fashion. The sum of a counter output and two sets of offsets are used to generate a read address. Once an initial starting column has been picked, the read address is generated by switching a read column offset at a rate that is equal to the horizontal scan rate of a video display. After reading one horizontal scans worth of data, the read counter is incremented and the read column offsets are changed at a rate equal to the horizontal scan rate of the display. As a result, the offset addresses are changing at the display's horizontal display rate and the counter is incremented at a rate equal to the vertical scan rate of a display. It is possible to read data out at a rate faster or slower than required by the video display; however, if read out faster, a buffer memory should be used, if read out slower the video display may appear choppy to the viewer.

It should be noted that the cylindrical arrangement of pixels of FIG. **8** is typically displayed on a flat or nearly flat display. As a result, the image is displayed by compensating for converting between a cylindrical surface and a flat surface. This may be carried out using a simple conversion algorithm within a common digital signal processing integrated circuit. Methods for these types of conversions are well known in the art and can be found in "A Guided Tour of Computer Vision," Vishvjit S. Nalwa, Addison-Wesley Publishing Co., Reading, Mass., 1993. It is also possible to carry out the conversion using a very high resolution display.

It should be noted that if the view selected by a user corresponds exactly to the view of a particular camera, such as camera **52**, columns **240-248** are read from memory **170**. Column **240** is the first column in segment **232** and column **248** is the last column in segment **232**. If the user decides to move the view in a counter-clockwise direction, the start column will shift to the right so that the read operation begins at column **246** and ends at column **250**. It should be noted that column **246** is the second column associated with memory segment **232** which has the pixel data from camera **52**, and that column **250** is the first column of pixel data associated with camera **56**. As the user shifts the view, the starting column shifts in relationship to the user's commands. For example, if the user indicates that the view should shift in a counter-clockwise direction, the start column of FIG. **9** moves to the right, similarly, if the viewer indicates that the view should shift in a clockwise direction, the start column shifts to the left. As before, columns are addressed by using offsets, if the offsets involve moving between memory segments, a read segment offset is added to the sum of the column offset and counter output.

It should be recalled that the columns near the sector boundaries of FIG. **8** are closer together. As a result, when the user commands a change in a view and when the border of that view is near a sector boundary, the start column changes by a larger number of columns for a given angular rotation of the view. Conversely, when the border of the view is near the center of the sector, the start column changes by a smaller number of columns for a given angular rotation.

FIG. **10** illustrates a block diagram of controller **174**. Controller **174** includes microprocessor **270** and memory

272. Memory **272** includes RAM and ROM. Processor **270** receives commands on line **274** from user input device **180**. Microprocessor **270** controls start, stop and reset of counter **276**. Counter **276** controls the select lines of mux **170**. Counter **276** counts at a rate that is four times the horizontal scan rate of the cameras. Write address generator **278** provides write addressing for memory **172**. Write address generator **278** includes a counter, register for storing offsets and adder for adding the offsets and counter output. Microprocessor **270** controls the offset selection and the counters used by write address generator **278**. The write addresses are formed as described with regard to FIG. **9**. Read address generator **280** provides read addresses to memory **172**. Read address generator **280** includes a counter, register for storing offsets and adder for adding the offsets and counter output. As with write address generator **278**, microprocessor **270** controls the offset selection and the counters of read address generator **280**. Microprocessor **270** also controls the starting column used by the counters based on inputs provided on line **274** from user input **180**.

The write and read addresses are provided to memory **172** separately if memory **172** is implemented using a two port memory. If memory **172** is implemented with a single port memory, the write and read addresses are multiplexed to memory **172**.

FIG. **11** illustrates an embodiment where a panoramic viewer is used to provide views to several users over a communications network. In this embodiment, all of the columns of pixel data are read from memory **172** and placed on bus **300**. Buffer memories **302**, **304**, **306** and **308** receive the data from bus **300**. The buffer memories are enabled only when desired columns are available on bus **300**. The buffer memories then pass their information to modems **310**, **312**, **314** and **316**, which then provide the pixel data to telecommunications network **318**. Telecommunications network **318** then delivers the information from the modems to the users. In one example, a user receives information from modem **316** using modem **320**. Modem **320** then provides the pixel information that was in memory **308** to a local video memory **322**. Video memory provides the pixel information to display **324** for viewing. The user at this location controls the view using user input device **326** which may be a device such as a mouse, keyboard or joystick. Modem **320** transmits the user input device signals over telecommunications network **318** to modem **316** which then provides the signals to enable controller **330**. Enable controller **330** receives a signal from controller **174** that indicates which column is being read from memory **172**. When the appropriate column is available, the enable controller **330** enables the buffer memory **308** to receive the columns of data specified by the user input device signals received over the communication network. As discussed with regard to FIG. **9**, enable controller **330** simply moves the start column based on signals from the user input device. In this embodiment, enable controller **330** enables the input to the buffer memory when the pixel data from the start column is on bus **300**. Enable controller **330** disables the input to the buffer memory when the total number of columns of pixels to be viewed are provided to the buffer memory. FIG. **11** illustrates a system where four users can individually control their viewing; however, more users may be accommodated by simply increasing the number of buffer memories, modems, and ports on enable controller **330**.

FIG. **12** illustrates another embodiment in which multiple viewers can use the panoramic viewer. As the pixel data is read from memory **172**, all of the data is passed over telecommunications network **318** to telecommunications

bridge 350. The information from memory 172 is provided to bridge 350 via modem 344; however, the data may be passed to bridge 350 without use of modem 344 if a digital connection is made between memory 172 and bridge 350. Bridge 350 then distributes all of the data received from memory 172 to each user in communication with bridge 350. If bridge 350 provides analog link to users, a modem should be used at each user port. If the bridge has a digital link to the user ports, a modem is not required. In the case of an analog link, the data from memory 172 passes from modem 344 via bridge 350 to modem 360 at a user port. Modem 360 passes the pixel data to video memory 362. Video memory 362 then passes the pixel information to video display 364 under control of a user via user input device 366. User input device may be a mouse, joystick or computer keyboard. In this embodiment, the entire contents of memory 172 is fed to video memory 362. The data read from memory 362 and passed to video display 364 is controlled using user input device 366 in a fashion similar to that which was described with regard to FIG. 9.

FIG. 13 illustrates the viewing system of FIG. 2 with a fifth camera. Camera or image gathering device 400 is located in pyramid 40 with the optical center of camera 400 located at virtual optical center 90. Camera 400 views objects in the direction of arrow 410. It is desirable to provide camera 400 with a wide angle lens. The resulting wide angle view coupled with the views of the remaining four cameras, provides a nearly spherical view. If the cameras of FIG. 13 are replaced with image producing devices, the nearly spherical viewing system becomes a nearly spherical projection system. It should be noted that a camera or projection device may be placed at the virtual optical center of viewing/projection devices having pyramids with three, four or more sides. It should also be noted that edges 420 of the reflective surfaces should be beveled to avoid undesirable obstruction of camera 400's field of view. It is also possible to avoid undesirable image artifacts from base edges 420 by moving camera or image processing device 400. Device 400 should be moved so that device 400's optical center is positioned away from virtual optical center 90 in the direction of arrow 410. Device 400's optical center should be positioned so that the device's field of view does not include edges 420.

FIG. 14 illustrates a top view of the pyramid of FIG. 2. In reference to FIG. 2, camera 52, 54, 56 and 58 have been moved upward in the direction of base 50. As a result, virtual optical centers 500, 502, 504 and 506, which correspond to cameras 52, 54, 56 and 58, respectively, are moved away from virtual optical center 90. It is desirable to move the virtual optical centers so that camera 52 captures an image between lines 508 and 510, camera 54 captures an image between lines 512 and 514, camera 56 captures an image between lines 516 and 518, and camera 58 captures an image between lines 520 and 522. This results in the cameras not capturing useful images from narrow planar shaped regions. In particular, planar regions 524, 526, 528 and 530 are not used by the cameras and form blind regions. This offers the advantage of removing portions of the cameras' fields of view that are received from the edges of the reflective pyramid. Eliminating these portions of the fields of view alleviates the need to provide image processing that compensates for image artifacts at the edges. It is desirable to keep virtual optical centers 500, 502, 504 and 506 closely clustered so that planes 524, 526, 528 and 530 are only as thin as necessary to avoid edge artifacts. By maintaining such thin planes, the need to process the images at their common boundaries is removed while minimizing the noticeable effect seen by a user.

From the foregoing description, it is readily apparent that moving the virtual optical centers outward, as in FIG. 14, facilitates the creation of a composite image that excludes images of mirror edges lying between portions of the fields of view of individual cameras. From the geometry that has been described, it is apparent that the mirror edges lie within, or are encompassed by, the blind regions of the composite field of view corresponding to the composite image. It is also apparent that the narrow planar shaped blind regions lie between portions of adjacent individual fields of view that extend outwardly in substantially similar directions, and that these blind regions do not expand in size with increasing distance from the viewing system. Such expansion of the blind regions would be undesirable because it would allow them to envelope objects that are increasingly large with increasing distance from the viewing system. As described earlier in reference to FIG. 7, the individual images, and the composite image, are stored as data in memory 172. Accordingly, eliminating portions of the individual fields of view corresponding to the blind regions of the composite field of view, as described above with reference to FIG. 14, results in a collection of stored data in memory 172 that excludes data representing images of mirror edges that lie within the blind regions, and it will be immediately apparent to those skilled in the art that the described exclusion of images of mirror edges from useful camera images may be accomplished by disregarding in memory 172, or discarding from this memory, image data that corresponds to portions of the fields of view of the cameras that contain these mirror edges.

FIG. 15 illustrates the pyramid of FIG. 14 with shades 560, 562, 564 and 566 positioned in planar regions 524, 526, 528, and 530, respectively. The shades reduce the amount of unwanted light that enters the cameras. Similar shades may be placed in blind regions between device 400's field of view and one or more of the other image processing devices' field of view. For example, if we recall that moving image device 400 in the direction of arrow 410 removes base edges 420 from the device's field of view, a shade may be placed in one or more of the planar blind regions that extend out from a base edge 420.

What is claimed is:

1. A method of producing a composite image with a plurality of sensors each having an individual field of view, comprising the steps of:

for at least one of the plurality of sensors, redirecting at least a portion of its individual field of view with a reflective area; and

merging images corresponding to the individual fields of view to produce the composite image having a corresponding field of view, wherein each one of at least two fields of view corresponding to images that are merged has a portion, where the images are merged, that has viewing directions that are substantially similar to the viewing directions of the other portion, and wherein the viewing directions within each one of such two portions appear to originate substantially from a point that is offset from the point for the other one of such two portions.

2. The method of claim 1, wherein the field of view corresponding to the composite image has at least one blind region that encompasses at least a portion of an edge of a reflective area and that lies between the two portions of the two individual fields of view.

3. The method of claim 2, wherein the number of sensors each of whose field of view is redirected at least in part by a reflective area is at least three.

11

4. The method of claim 2, wherein the number of sensors each of whose field of view is redirected at least in part by a reflective area is at least five.

5. The method of claim 1, wherein images corresponding to the individual fields of view are merged electronically by merging data representative of the fields of view to produce data representative of the composite image and data representative of the composite image is stored by electronic means.

6. The method of claim 5, further comprising displaying the composite image selectively using a control means to select a portion of the composite image to be displayed.

7. The method of claim 6, wherein the number of sensors each of whose field of view is redirected at least in part by a reflective area is at least three.

8. The method of claim 6, wherein the number of sensors each of whose field of view is redirected at least in part by a reflective area is at least five.

9. The method of claim 5, further comprising displaying at least a portion of the composite image remotely after transmitting this portion over a communication network.

10. The method of claim 9, wherein the number of sensors each of whose field of view is redirected at least in part by a reflective area is at least three.

11. The method of claim 9, wherein the number of sensors each of whose field of view is redirected at least in part by a reflective area is at least five.

12. The method of claim 5, wherein the number of sensors each of whose field of view is redirected at least in part by a reflective area is at least three.

13. The method of claim 5, wherein the number of sensors each of whose field of view is redirected at least in part by a reflective area is at least five.

14. The method of claim 1, wherein the number of sensors each of whose field of view is redirected at least in part by a reflective area is at least three.

15. The method of claim 1, wherein the number of sensors each of whose field of view is redirected at least in part by a reflective area is at least five.

16. A viewing apparatus having a composite field of view, comprising:

at least two image sensors, each having an individual field of view;

at least one reflective area that redirects at least part of the individual field of view associated with one of the image sensors,

the individual fields of view of at least two image sensors being merged to produce the composite field of view, at least portions of each of the two individual merged fields of view having substantially similar viewing directions where they are merged, and the merged fields of view creating in the composite field of view at least one blind region that encompasses at least a portion of an edge of the reflective area and that lies between portions of two individual fields of view; and

a memory for storing data representative of said composite field of view electronically.

17. The viewing apparatus of claim 16, wherein the number of sensors each of whose individual field of view is redirected at least in part by a reflective area is at least three.

18. The viewing apparatus of claim 16, wherein the number of sensors each of whose individual field of view is redirected at least in part by a reflective area is at least five.

19. A viewing apparatus having a composite field of view, comprising:

at least two image sensors, each having an individual field of view;

12

at least one reflective area that redirects at least part of the individual field of view associated with one of the image sensors,

the individual fields of view of at least two image sensors being merged to produce the composite field of view, at least portions of each of the two merged individual fields of view having substantially similar viewing directions where they are merged, and the merged fields of view creating in the composite field of view at least one blind region that encompasses at least a portion of an edge of the reflective area and that lies between portions of two individual fields of view;

a memory for storing data representative of said composite field of view electronically; and

control means for selectively retrieving said data from said memory in response to user signals produced in response to a user's input.

20. The viewing apparatus of claim 19, wherein the number of sensors each of whose individual field of view is redirected at least in part by a reflective area is at least three.

21. The viewing apparatus of claim 19, wherein the number of sensors each of whose individual field of view is redirected at in part by a reflective area is at least five.

22. A viewing apparatus having a composite field of view, comprising:

at least two image sensors, each having an individual field of view; at least one reflective area that redirects at least part of the individual field of view associated with one of the image sensors,

the individual fields of view of at least two images sensors being merged to produce the composite field of view, at least portions of each of the two merged individual fields of view having substantially similar viewing directions where they are merged, and the merged fields of view creating in the composite field of view at least one blind region that encompasses at least a portion of an edge of the reflective area and that lies between portions of two individual fields of view;

a memory for storing data representative of said composite field of view electronically;

control means for selectively retrieving said data from said memory in response to user signals produced in response to a users input; and

communication network interface means for transmitting said data retrieved from said memory over a communications network and for receiving said user signals over said communications network.

23. The viewing apparatus of claim 22, wherein the number of sensors each of whose individual field of view is redirected at least in part by a reflective area is at least three.

24. The viewing apparatus of claim 22, wherein the number of sensors each of whose individual field of view is redirected at least in part by a reflective area is at least five.

25. A composite image produce with a plurality of sensors each having an individual field of view, by following the method of:

for at least one of the plurality of sensors, redirecting at least a portion of its individual field of view with a reflective area; and

merging images corresponding to the individual fields of view to produce the composite image having a corresponding field of view, wherein each one of at least two fields of view corresponding to images that are merged has a portion, where the images are merged, that has viewing directions that are substantially similar to the

13

viewing directions of the other portion, and wherein the viewing directions within each one of such two portions appear to originate substantially from a point that is offset from the point for the other one of such two portions.

26. The composite image of claim 25, wherein the field of view corresponding to the composite image has at least one blind region that encompasses at least a portion of an edge of a reflective area and that lies between the two portions of the two individual fields of view.

27. The method of claim 26 wherein the number of sensors each of whose field of view is redirected at least in part by a reflective area is at least three.

28. The method of claim 26 wherein the number of sensors each of whose field of view is redirected at least in part by a reflective area is at least five.

29. The composite image of claim 25, wherein images corresponding to the individual fields of view are merged electronically by merging data representative of the fields of view to produce data representative of the composite image and data representative of the composite image is stored by electron means.

30. The composite image of claim 29, wherein a portion of the composite image is displayed selectively using a control means to select the portion of the composite image to be displayed.

31. The method of claim 30 wherein the number of sensors each of whose field of view is redirected at least in part by a reflective area is at least three.

14

32. The method of claim 30 wherein the number of sensors each of whose field of view is redirected at least in part by a reflective area is at least five.

33. The composite image of claim 29, wherein at least a portion of the composite image is displayed remotely after this portion is transmitted over a communication network.

34. The method of claim 33 wherein the number of sensors each of whose field of view is redirected at least in part by a reflective area is at least three.

35. The method of claim 33 wherein the number of sensors each of whose field of view is redirected at least in part by a reflective area is at least five.

36. The method of claim 29 wherein the number of sensors each of whose field of view is redirected at least in part by a reflective area is at least three.

37. The method of claim 29 wherein the number of sensors each of whose field of view is redirected at least in part by a reflective area is at least five.

38. The method of claim 25, wherein the number of sensors each of whose field of view is redirected at least in part by a reflective area is at least three.

39. The method of claim 25, wherein the number of sensors each of whose field of view is redirected at least in part by a reflective area is at least five.

* * * * *



US006700711C1

(12) **INTER PARTES REEXAMINATION CERTIFICATE** (1619th)
United States Patent
Nalwa

(10) **Number:** **US 6,700,711 C1**
(45) **Certificate Issued:** ***Oct. 16, 2019**

(54) **PANORAMIC VIEWING SYSTEM WITH A COMPOSITE FIELD OF VIEW**

H04N 5/74 (2013.01); *H04N 7/181* (2013.01);
G03B 17/17 (2013.01); *G03B 37/04* (2013.01)

(76) **Inventor:** **Vishvjit Singh Nalwa**, Holmdel, NJ
(US)

(58) **Field of Classification Search**
None
See application file for complete search history.

Reexamination Request:
No. 95/001,876, Jan. 26, 2012

(56) **References Cited**

Reexamination Certificate for:
Patent No.: **6,700,711**
Issued: **Mar. 2, 2004**
Appl. No.: **10/093,568**
Filed: **Mar. 8, 2002**

To view the complete listing of prior art documents cited during the proceeding for Reexamination Control Number 95/001,876, please refer to the USPTO's public Patent Application Information Retrieval (PAIR) system under the Display References tab.

(*) **Notice:** This patent is subject to a terminal disclaimer.

Primary Examiner — Deandra M Hughes

Related U.S. Application Data

(63) Continuation of application No. 09/431,400, filed on Dec. 27, 1999, now Pat. No. 6,356,397, which is a continuation of application No. 08/946,443, filed on Oct. 7, 1997, now Pat. No. 6,111,702, which is a continuation-in-part of application No. 08/565,501, filed on Nov. 30, 1995, now Pat. No. 6,115,176.

(57) **ABSTRACT**

Cameras are positioned so that at least a portion of the field of view of at least one camera is redirected by a reflective surface. Images from these cameras are merged to produce a composite image while disregarding at least a portion of a camera's field of view such that there is at least one blind region in the composite field of view. Advantageously, such blind regions can be made to encompass edges of mirror surfaces that would otherwise produce image artifacts in the composite image; this can be accomplished without introducing gaps in the angular span of the composite field of view. Data representative of the composite image is stored in a memory from which it may be retrieved selectively using a control means to display a portion of the composite image. The image and control data may be transmitted over a communication network to facilitate remote control and display.

(51) **Int. Cl.**
G02B 13/06 (2006.01)
G02B 5/04 (2006.01)
G02B 27/14 (2006.01)
H04N 5/225 (2006.01)
G02B 27/10 (2006.01)
H04N 5/268 (2006.01)
H04N 7/18 (2006.01)
H04N 5/74 (2006.01)
G03B 37/04 (2006.01)
G03B 17/17 (2006.01)

(52) **U.S. Cl.**
CPC **G02B 5/04** (2013.01); **G02B 27/1066**
(2013.01); **G02B 27/143** (2013.01); **H04N**
5/2259 (2013.01); **H04N 5/268** (2013.01);

Attention is directed to the decision of *Polycom, Inc. v. Fullview, Inc.* CAFC 2018-1829 April 29, 2019 relating to this patent. This reexamination may not have resolved all questions raised by this decision. See 37 CFR 1.552(c) for *ex parte* reexamination and 37 CFR 1.906(c) for *inter partes* reexamination.

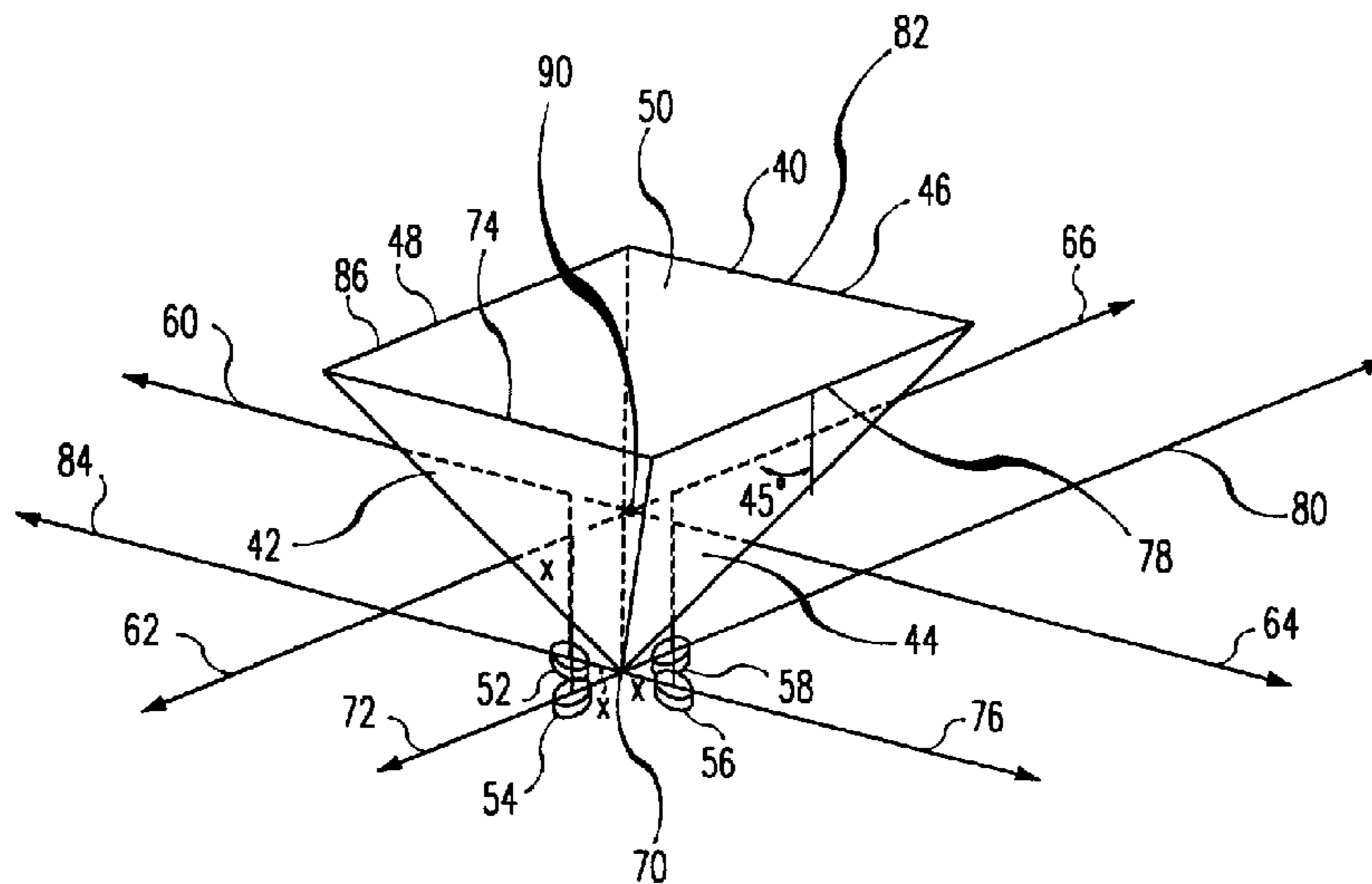

**INTER PARTES
REEXAMINATION CERTIFICATE**

NO AMENDMENTS HAVE BEEN MADE TO 5
THE PATENT

AS A RESULT OF REEXAMINATION, IT HAS BEEN
DETERMINED THAT:

The patentability of claims **1-21** and **25-39** is confirmed. 10
Claims **22-24** were not reexamined.

* * * * *